

# Networks Connect Us

Communication is almost as important to us as our reliance on air, water, food, and shelter. In today's world, through the use of networks, we are connected like never before.

# Video – The Cisco Networking Academy Learning Experience

Cisco Networking Academy: learn how we use technology to make the world a better place.



# Networking Today

## No Boundaries

- World without boundaries
- Global communities
- Human network



# 1.2 Network Components

# Network Components

## Host Roles

Every computer on a network is called a host or end device.

Servers are computers that provide information to end devices:

- email servers
- web servers
- file server

Clients are computers that send requests to the servers to retrieve information:

- web page from a web server
- email from an email server



| Server Type | Description  |
|-------------|--|
| Email       | Email server runs email server software. Clients use client software to access email.  |
| Web         | Web server runs web server software. Clients use browser software to access web pages. |
| File        | File server stores corporate and user files. The client devices access these files.    |

# Network Components

## Peer-to-Peer

It is possible to have a device be a client and a server in a Peer-to-Peer Network. This type of network design is only recommended for very small networks.

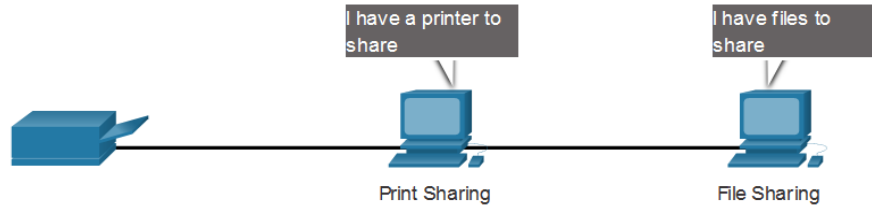

### Advantages

Easy to set up

Less complex

Lower cost

Used for simple tasks: transferring files and sharing printers

### Disadvantages

No centralized administration

Not as secure

Not scalable

Slower performance

# Network Components

## End Devices

An end device is where a message originates from or where it is received. Data originates with an end device, flows through the network, and arrives at an end device.

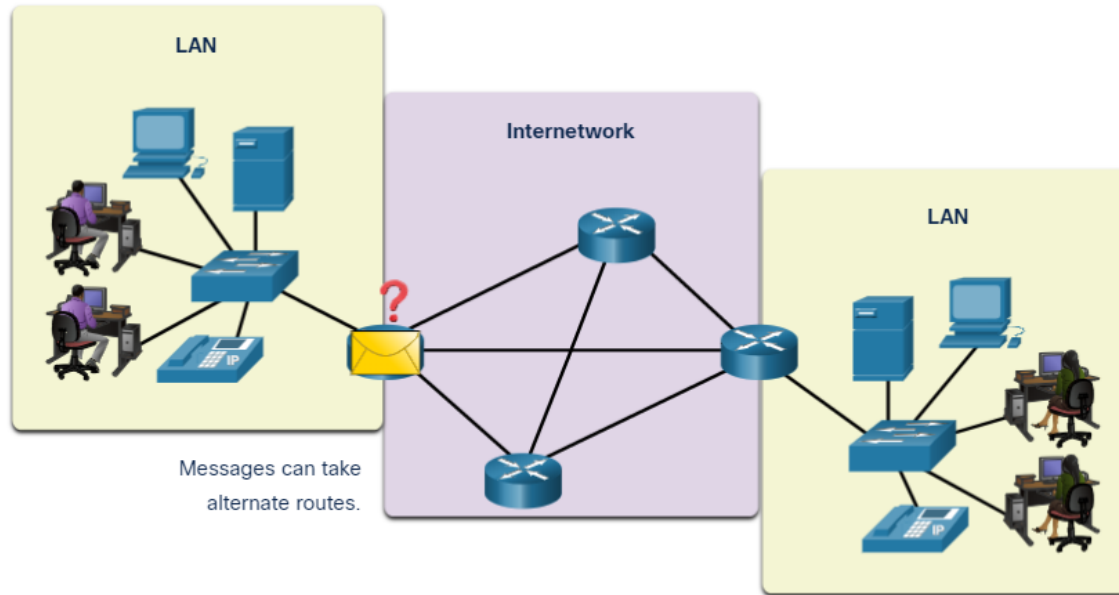

# Intermediary Network Devices

An intermediary device interconnects end devices. Examples include switches, wireless access points, routers, and firewalls.

Management of data as it flows through a network is also the role of an intermediary device, including:

- Regenerate and retransmit data signals.
- Maintain information about what pathways exist in the network.
- Notify other devices of errors and communication failures.

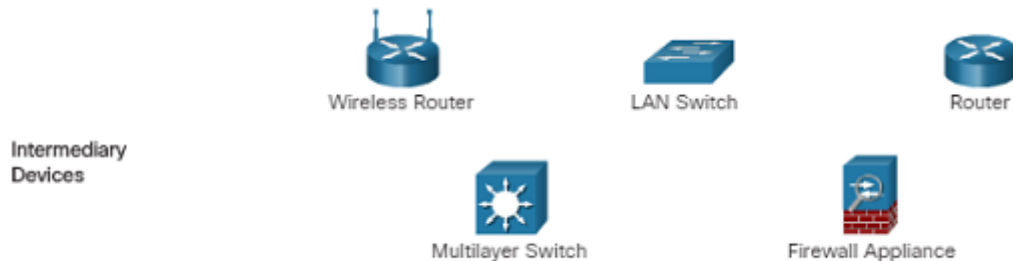



# Network Components

## Network Media

Communication across a network is carried through a medium which allows a message to travel from source to destination.

| Media Types   | Description   |
|---|---|
| Metal wires within cables                                 | Uses electrical impulses  |
| Glass or plastic fibers within cables (fiber-optic cable) | Uses pulses of light.   |
| Wireless transmission                                     | Uses modulation of specific frequencies of electromagnetic waves. |

Copper

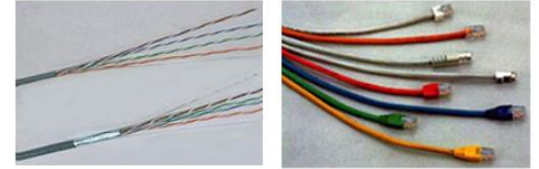

Fiber-optic



Wireless



# 1.3 Network Representations and Topologies

# Network Representations and Topologies

## Network Representations

Network diagrams, often called topology diagrams, use symbols to represent devices within the network.

Important terms to know include:

- Network Interface Card (NIC)
- Physical Port
- Interface

**Note:** Often, the terms port and interface are used interchangeably

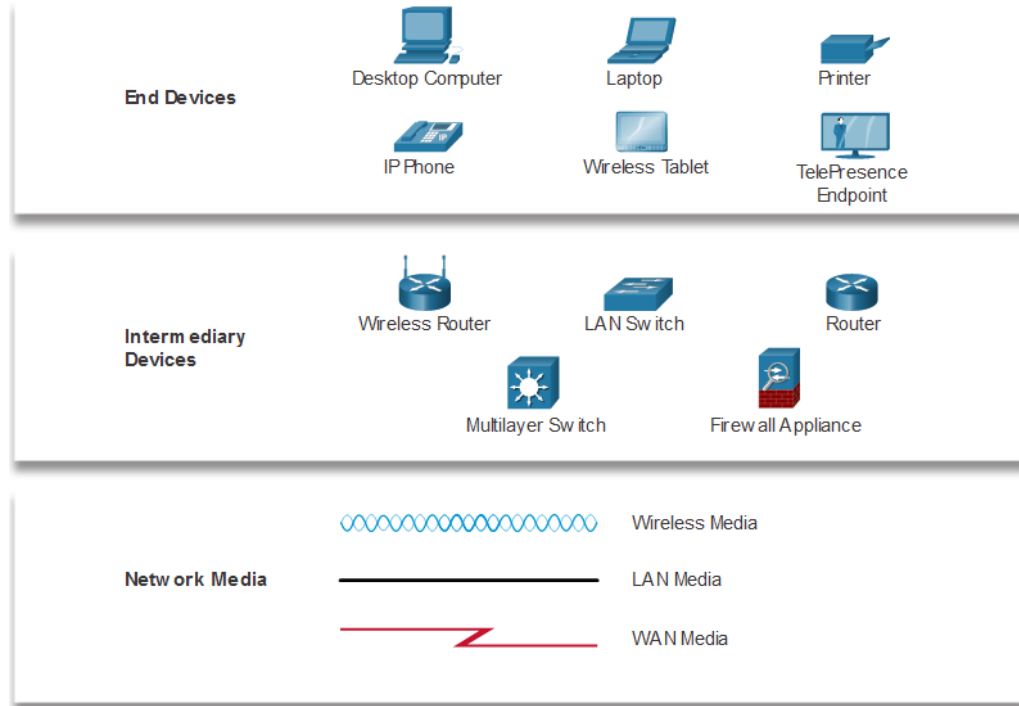

# Network Representations and Topologies

## Topology Diagrams

Physical topology diagrams illustrate the physical location of intermediary devices and cable installation.

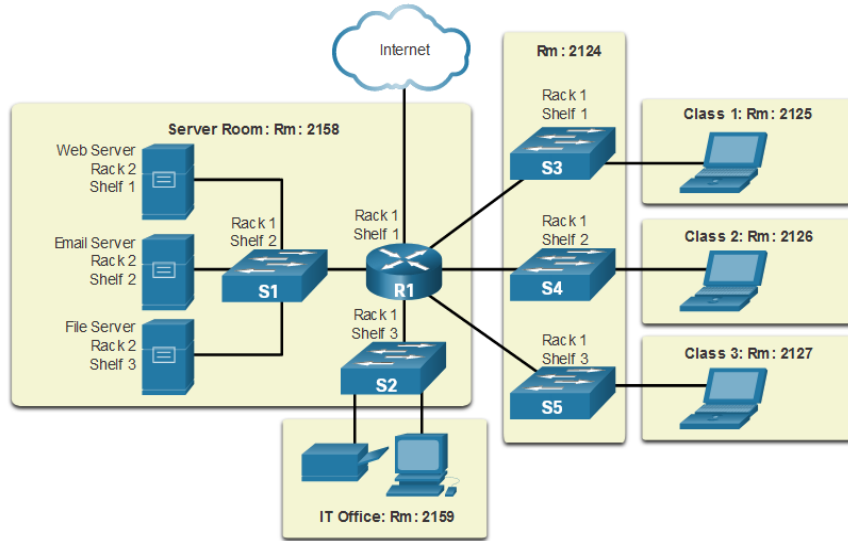

Logical topology diagrams illustrate devices, ports, and the addressing scheme of the network.

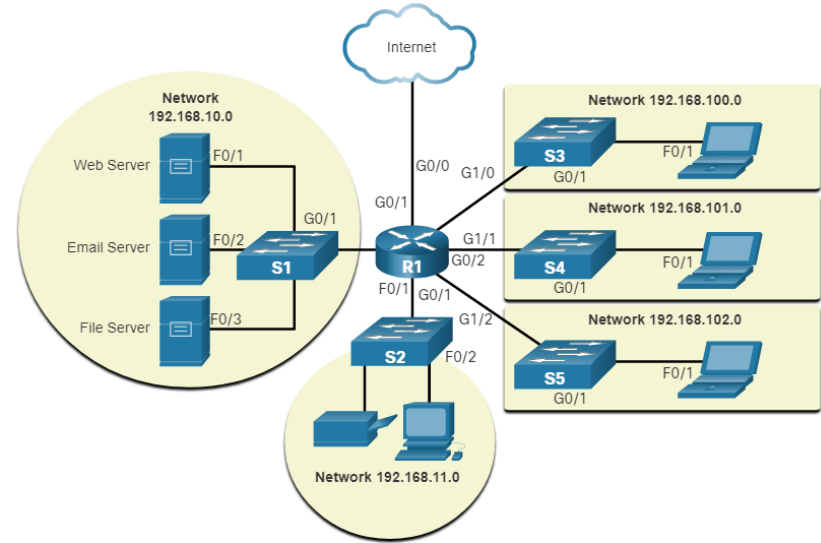

# 1.4 Common Types of Networks

# Networks of Many Sizes



Small Home



SOHO



Medium/Large



World Wide

- Small Home Networks – connect a few computers to each other and the Internet
- Small Office/Home Office – enables computer within a home or remote office to connect to a corporate network
- Medium to Large Networks – many locations with hundreds or thousands of interconnected computers
- World Wide Networks – connects hundreds of millions of computers world-wide – such as the internet

# Common Types of Networks

## LANs and WANs

Network infrastructures vary greatly in terms of:

- Size of the area covered
- Number of users connected
- Number and types of services available
- Area of responsibility

Two most common types of networks:

- Local Area Network (LAN)
- Wide Area Network (WAN).

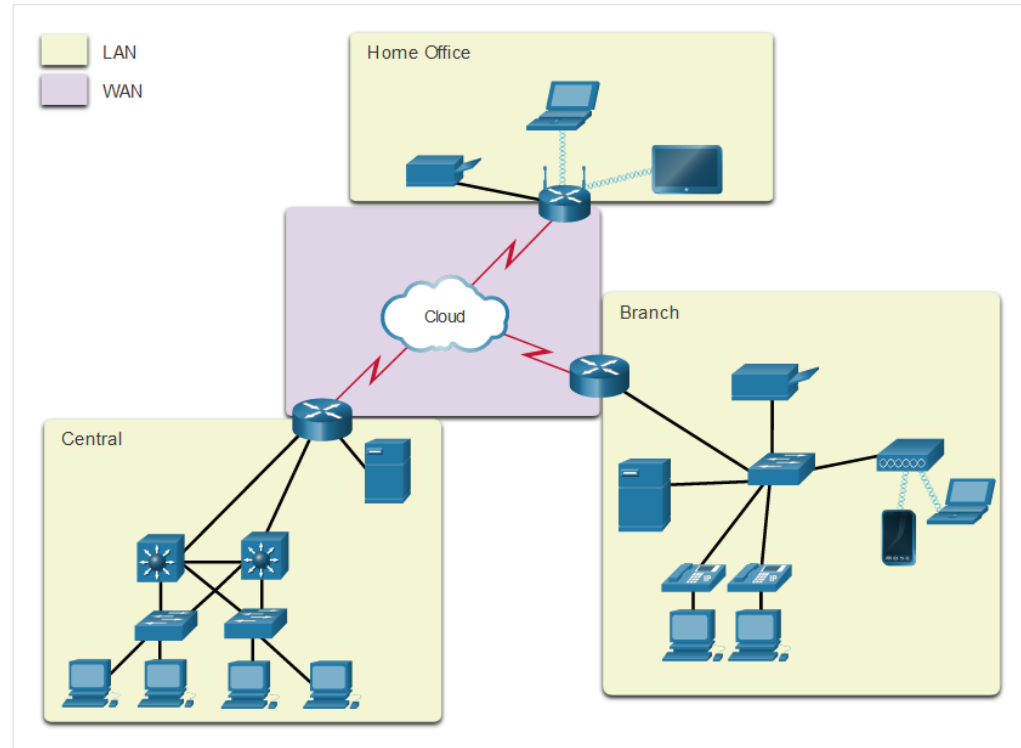

## Common Types of Networks

# LANs and WANs (cont.)

A LAN is a network infrastructure that spans a small geographical area.

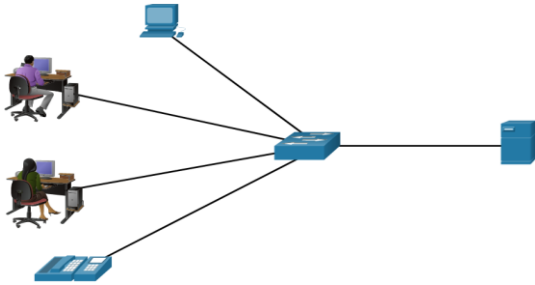

A WAN is a network infrastructure that spans a wide geographical area.

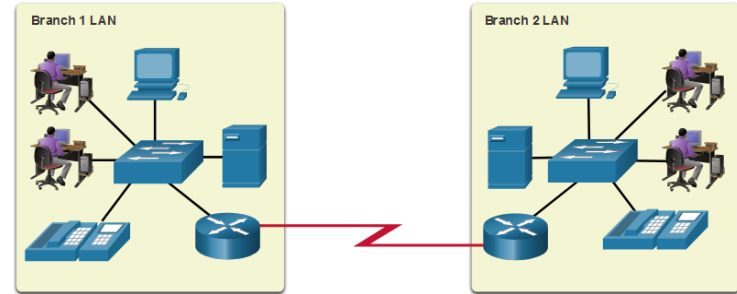

### LAN

Interconnect end devices in a limited area.

Administered by a single organization or individual.

Provide high-speed bandwidth to internal devices.

### WAN

Interconnect LANs over wide geographical areas.

Typically administered by one or more service providers.

Typically provide slower speed links between LANs.



# The Internet

The internet is a worldwide collection of interconnected LANs and WANs.

- LANs are connected to each other using WANs.
- WANs may use copper wires, fiber optic cables, and wireless transmissions.

The internet is not owned by any individual or group. The following groups were developed to help maintain structure on the internet:

- IETF
- ICANN
- IAB

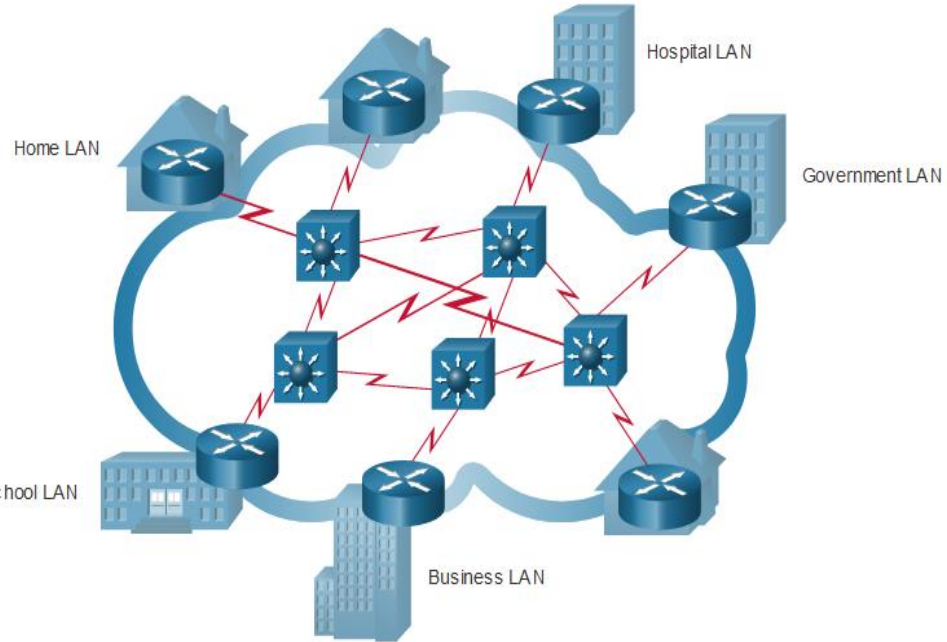

# Intranets and Extranets

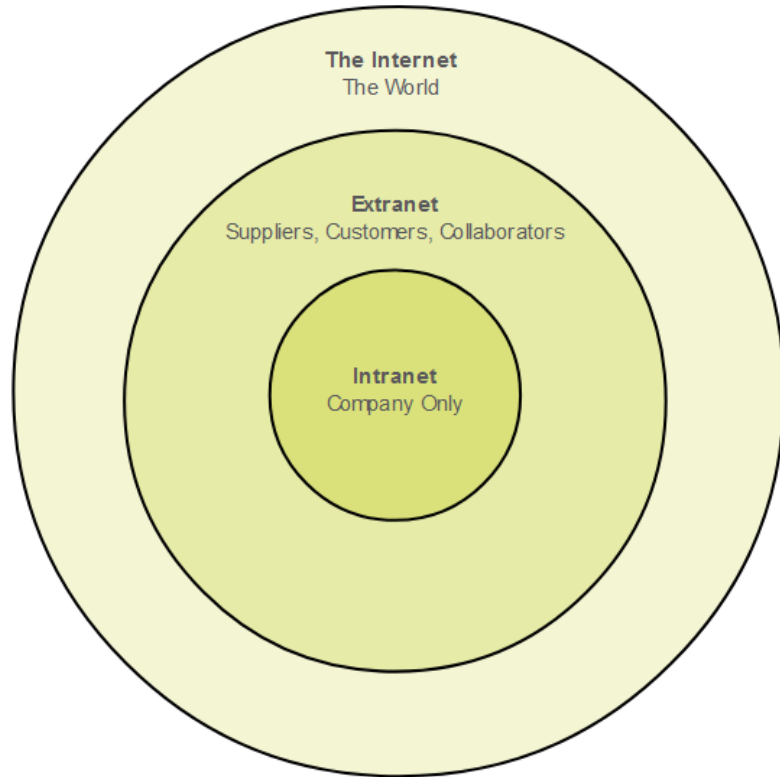

An intranet is a private collection of LANs and WANs internal to an organization that is meant to be accessible only to the organization's members or others with authorization.

An organization might use an extranet to provide secure access to their network for individuals who work for a different organization that need access to their data on their network.

# 1.5 Internet Connections

# Internet Access Technologies



There are many ways to connect users and organizations to the internet:

- Popular services for home users and small offices include broadband cable, broadband digital subscriber line (DSL), wireless WANs, and mobile services.
- Organizations need faster connections to support IP phones, video conferencing and data center storage.
- Business-class interconnections are usually provided by service providers (SP) and may include: business DSL, leased lines, and Metro Ethernet.

# Home and Small Office Internet Connections

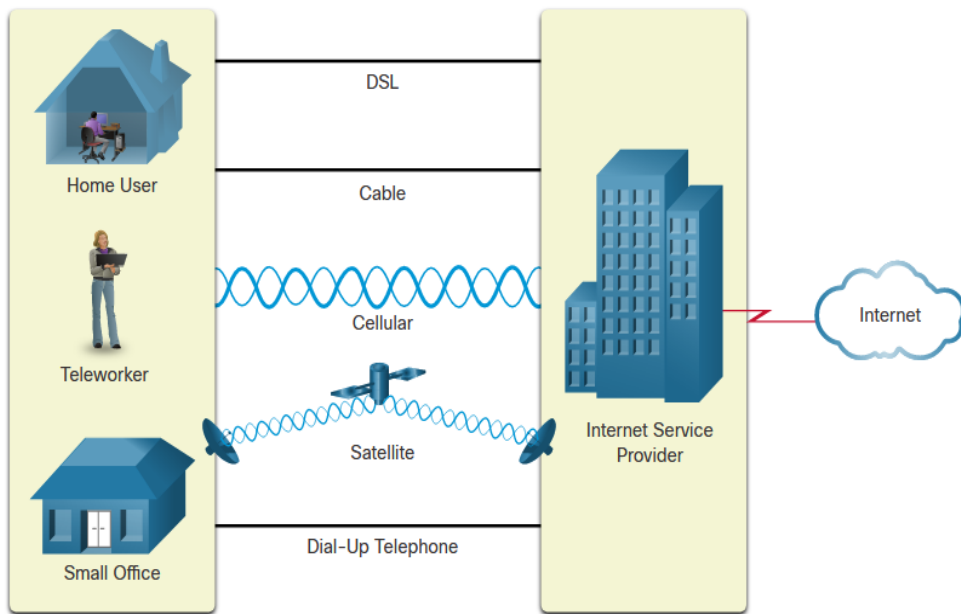

| Connection        | Description  |
|-------------------|--|
| Cable             | high bandwidth, always on, internet offered by cable television service providers. |
| DSL               | high bandwidth, always on, internet connection that runs over a telephone line.    |
| Cellular          | uses a cell phone network to connect to the internet.                              |
| Satellite         | major benefit to rural areas without Internet Service Providers.                   |
| Dial-up telephone | an inexpensive, low bandwidth option using a modem.                                |

# Businesses Internet Connections

Corporate business connections may require:

- higher bandwidth
- dedicated connections
- managed services

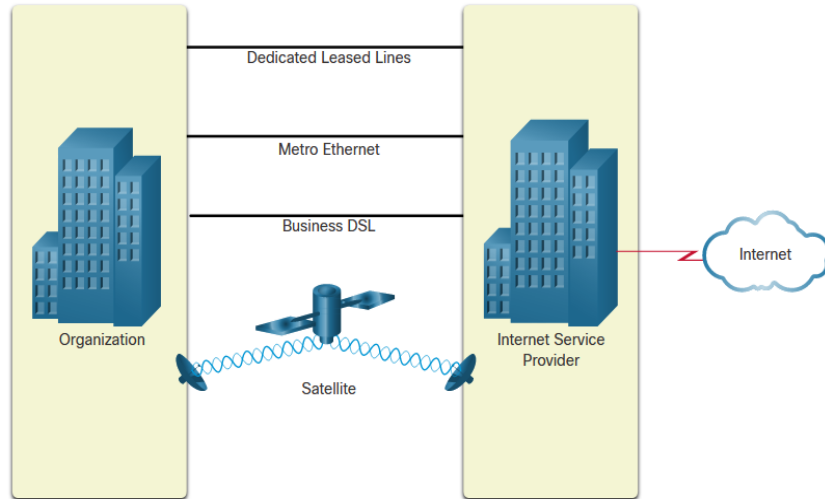

| Type of Connection    | Description   |
|-----------------------|---|
| Dedicated Leased Line | These are reserved circuits within the service provider's network that connect distant offices with private voice and/or data networking. |
| Ethernet WAN          | This extends LAN access technology into the WAN.  |
| DSL                   | Business DSL is available in various formats including Symmetric Digital Subscriber Lines (SDSL).   |
| Satellite             | This can provide a connection when a wired solution is not available.   |

# The Converging Network

Before converged networks, an organization would have been separately cabled for telephone, video, and data. Each of these networks would use different technologies to carry the signal.

Each of these technologies would use a different set of rules and standards.

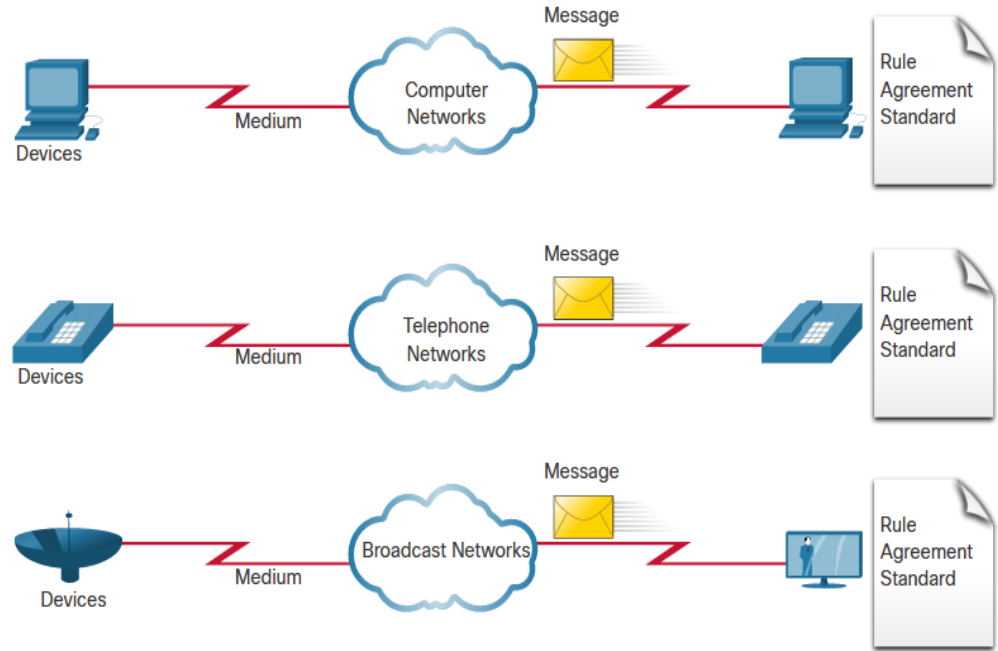

# The Converging Network (Cont.)

Converged data networks carry multiple services on one link including:

- data
- voice
- video

Converged networks can deliver data, voice, and video over the same network infrastructure. The network infrastructure uses the same set of rules and standards.

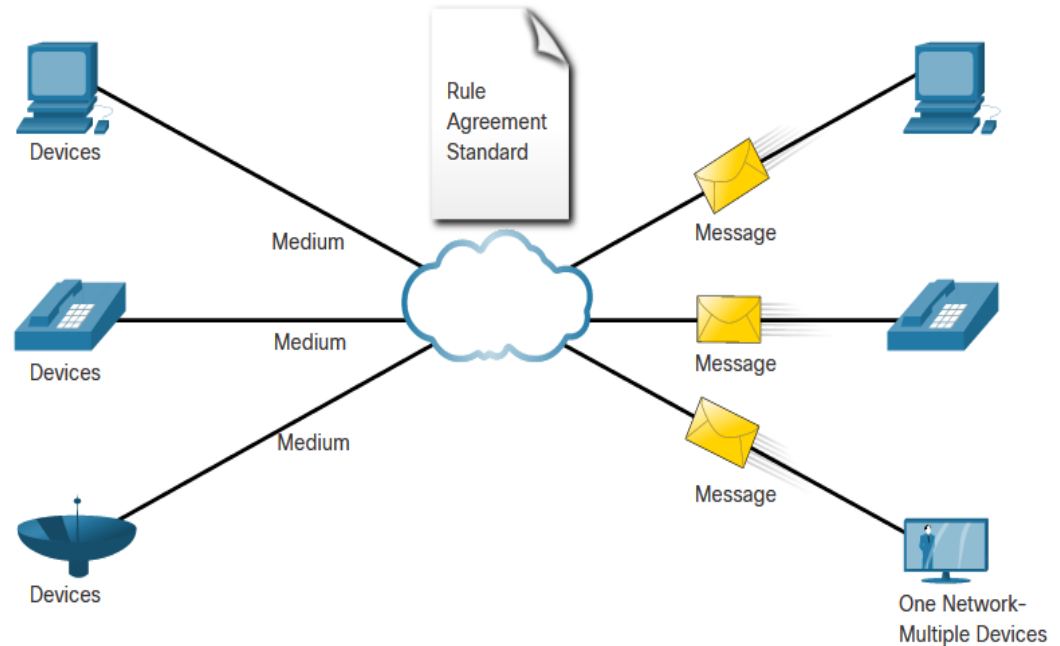



# 1.6 Reliable Networks

# Network Architecture

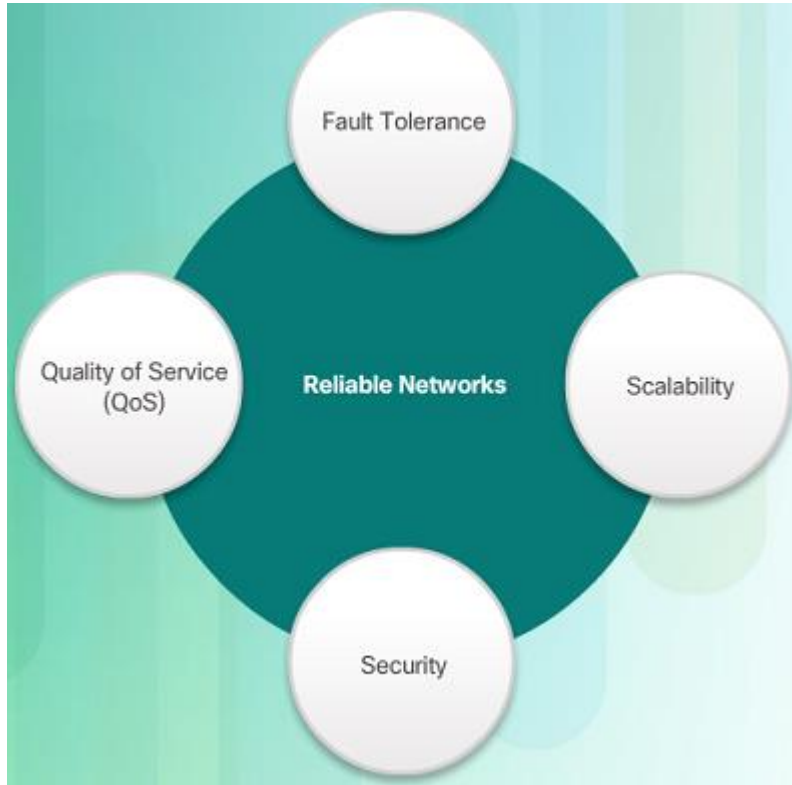

Network Architecture refers to the technologies that support the infrastructure that moves data across the network.

There are four basic characteristics that the underlying architectures need to address to meet user expectations:

- Fault Tolerance
- Scalability
- Quality of Service (QoS)
- Security

# Fault Tolerance

A fault tolerant network limits the impact of a failure by limiting the number of affected devices. Multiple paths are required for fault tolerance.

Reliable networks provide redundancy by implementing a packet switched network:

- Packet switching splits traffic into packets that are routed over a network.
- Each packet could theoretically take a different path to the destination.

This is not possible with circuit-switched networks which establish dedicated circuits.

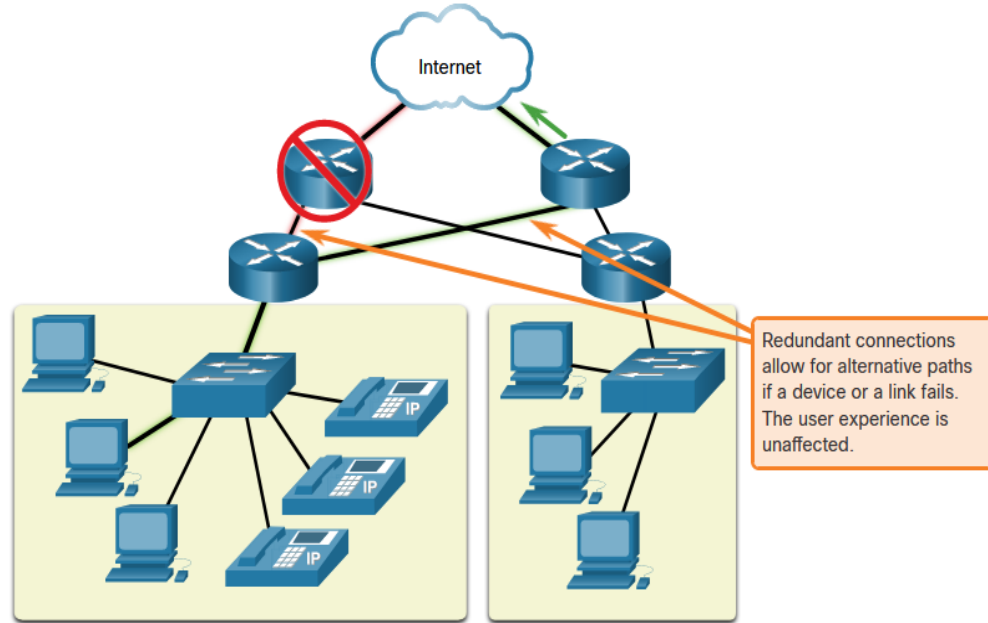

# Reliable Network Scalability

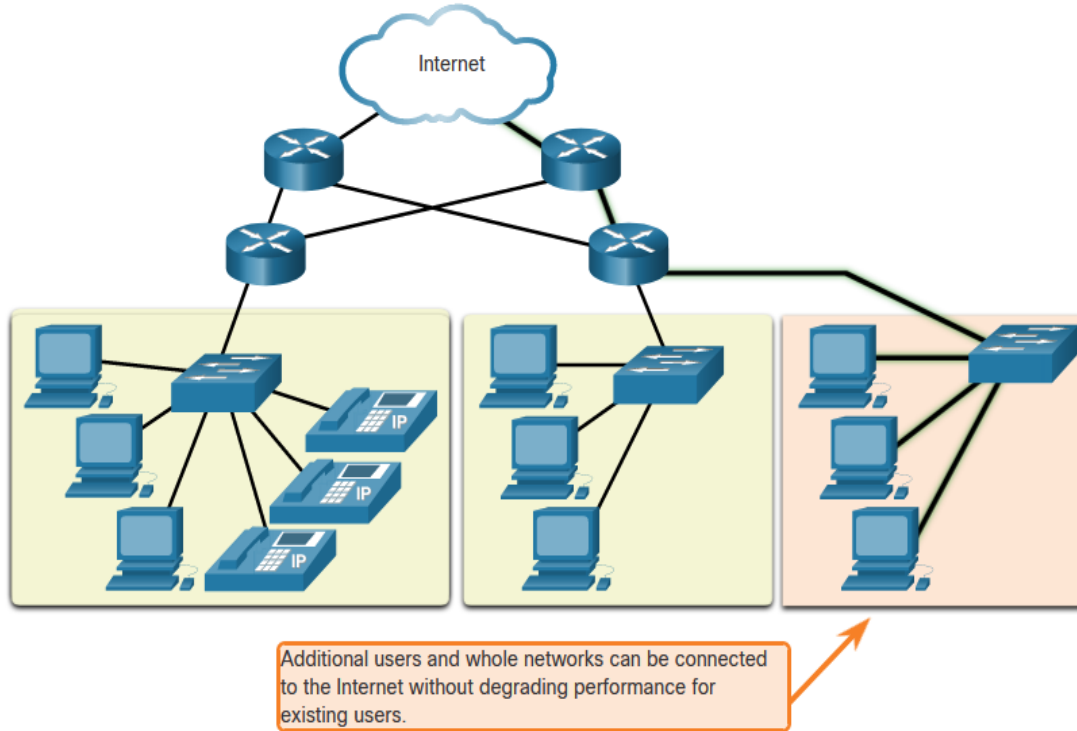

A scalable network can expand quickly and easily to support new users and applications without impacting the performance of services to existing users.

Network designers follow accepted standards and protocols in order to make the networks scalable.

# Reliable Network

## Quality of Service

Voice and live video transmissions require higher expectations for those services being delivered.

Have you ever watched a live video with constant breaks and pauses? This is caused when there is a higher demand for bandwidth than available – and QoS isn't configured.

- Quality of Service (QoS) is the primary mechanism used to ensure reliable delivery of content for all users.
- With a QoS policy in place, the router can more easily manage the flow of data and voice traffic.

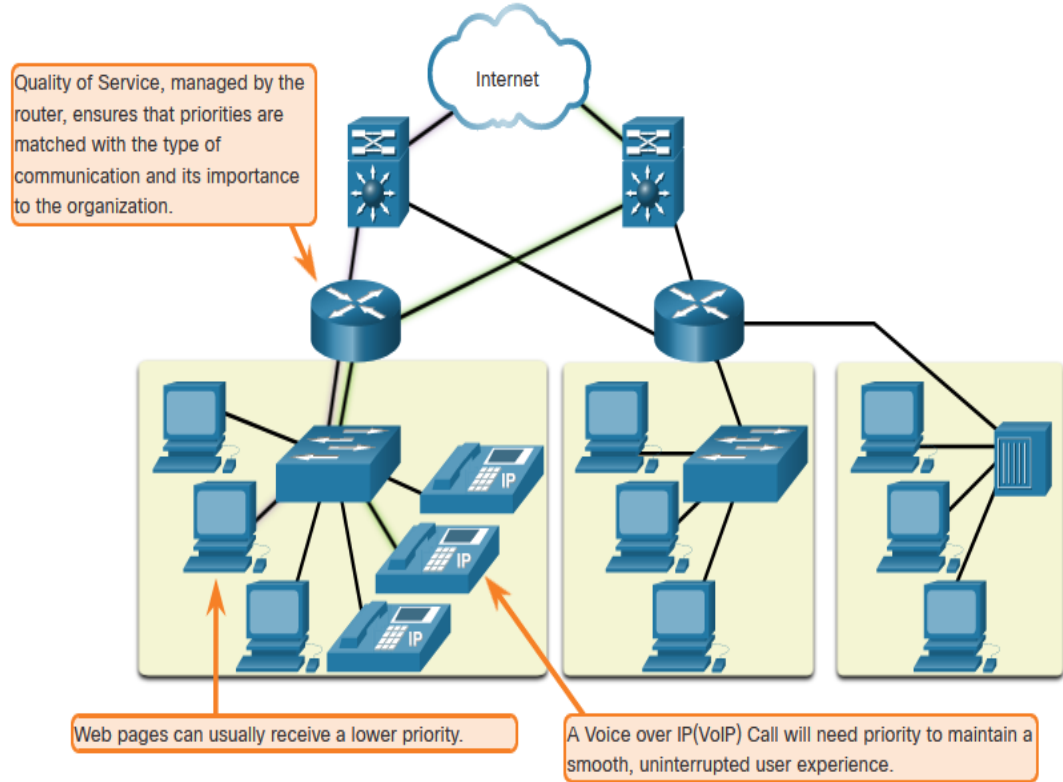

# Reliable Network

## Network Security

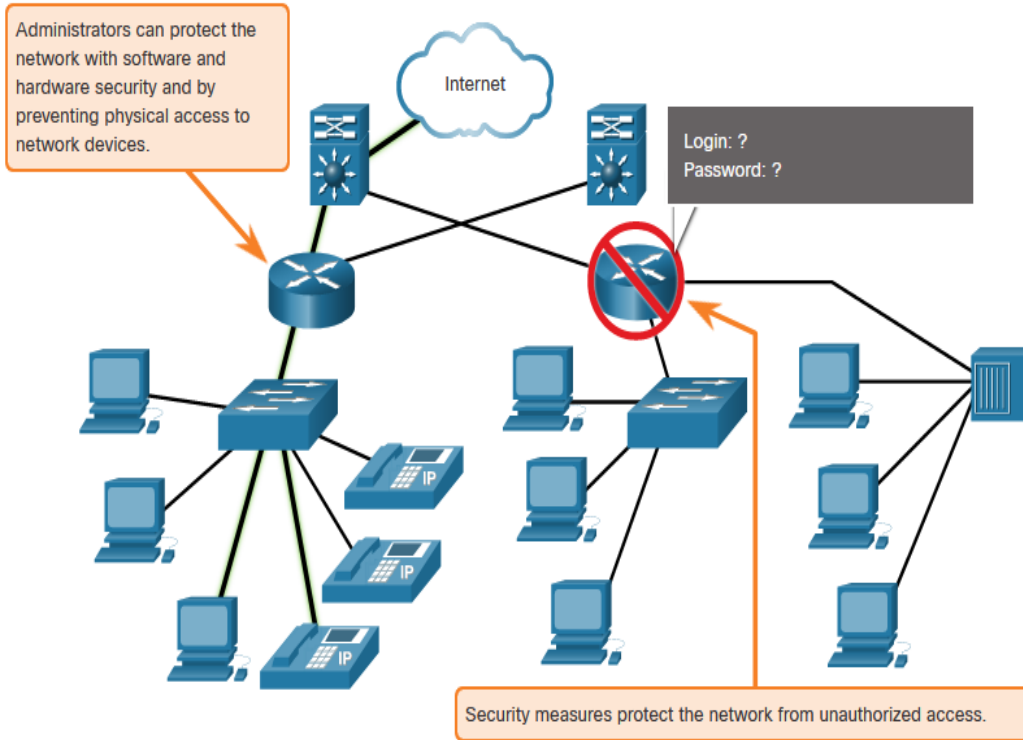

There are two main types of network security that must be addressed:

- Network infrastructure security
  - Physical security of network devices
  - Preventing unauthorized access to the devices
- Information Security
  - Protection of the information or data transmitted over the network

Three goals of network security:

- Confidentiality – only intended recipients can read the data
- Integrity – assurance that the data has not be altered with during transmission
- Availability – assurance of timely and reliable access to data for authorized users

# 1.7 Network Trends

# Network Trends

## Recent Trends



The role of the network must adjust and continually transform in order to be able to keep up with new technologies and end user devices as they constantly come to the market.

Several new networking trends that effect organizations and consumers:

- Bring Your Own Device (BYOD)
- Online collaboration
- Video communications
- Cloud computing



# Bring Your Own Device

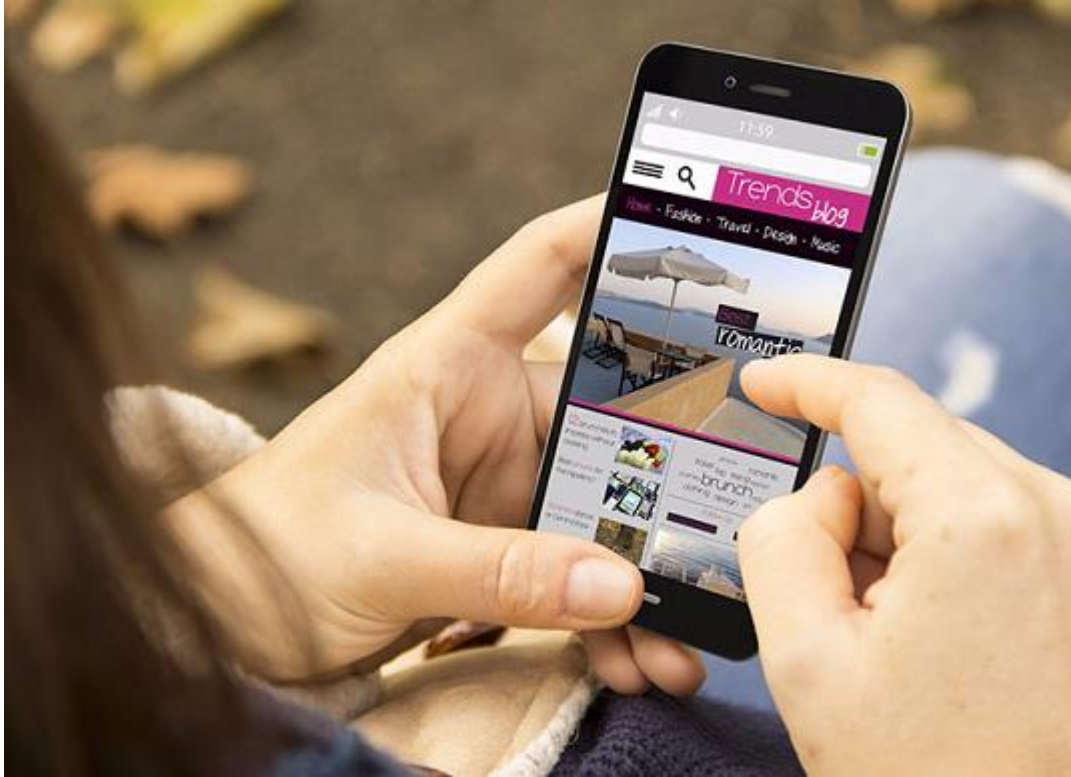

Bring Your Own Device (BYOD) allows users to use their own devices giving them more opportunities and greater flexibility.

BYOD allows end users to have the freedom to use personal tools to access information and communicate using their:

- Laptops
- Netbooks
- Tablets
- Smartphones
- E-readers

BYOD means any device, with any ownership, used anywhere.

# Network Trends

## Online Collaboration



- Collaborate and work with others over the network on joint projects.
- Collaboration tools including Cisco WebEx (shown in the figure) gives users a way to instantly connect and interact.
- Collaboration is a very high priority for businesses and in education.
- Cisco Webex Teams is a multifunctional collaboration tool.
  - send instant messages
  - post images
  - post videos and links

## Video Communication

- Video calls are made to anyone, regardless of where they are located.
- Video conferencing is a powerful tool for communicating with others.
- Video is becoming a critical requirement for effective collaboration.
- Cisco TelePresence powers is one way of working where everyone, everywhere.

# Cloud Computing

Cloud computing allows us to store personal files or backup our data on servers over the internet.

- Applications can also be accessed using the Cloud.
- Allows businesses to deliver to any device anywhere in the world.

Cloud computing is made possible by data centers.

- Smaller companies that can't afford their own data centers, lease server and storage services from larger data center organizations in the Cloud.

# Cloud Computing (Cont.)

Four types of Clouds:

- Public Clouds
  - Available to the general public through a pay-per-use model or for free.
- Private Clouds
  - Intended for a specific organization or entity such as the government.
- Hybrid Clouds
  - Made up of two or more Cloud types – for example, part custom and part public.
  - Each part remains a distinctive object but both are connected using the same architecture.
- Custom Clouds
  - Built to meet the needs of a specific industry, such as healthcare or media.
  - Can be private or public.

# Technology Trends in the Home

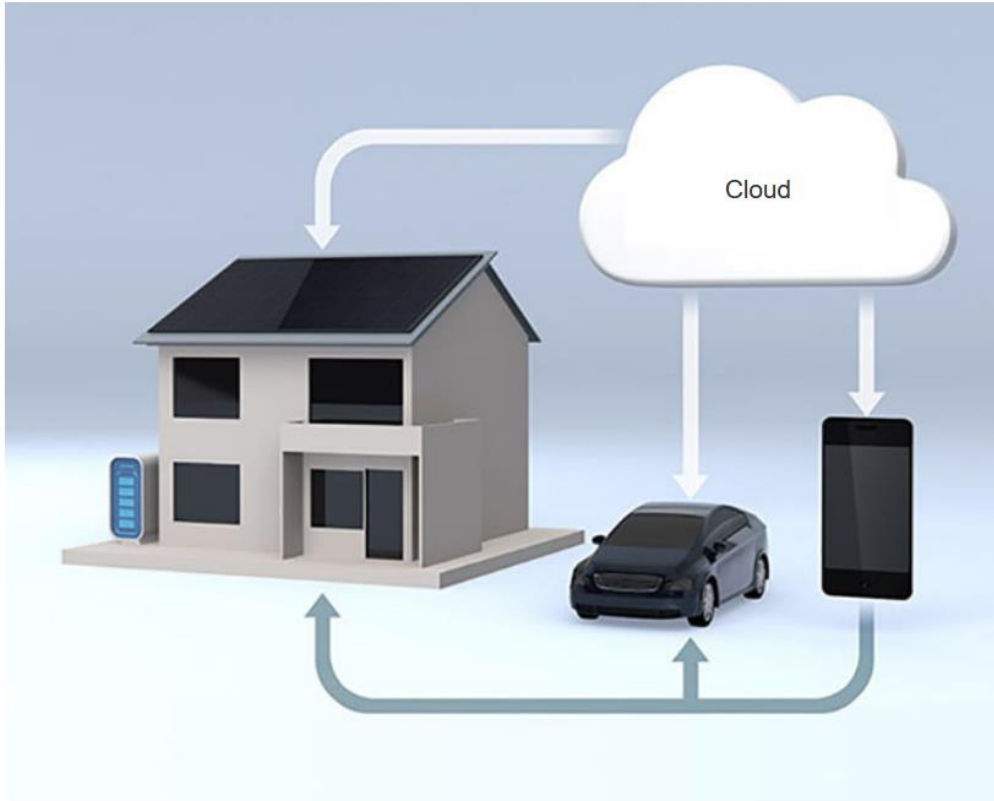

- Smart home technology is a growing trend that allows technology to be integrated into every-day appliances which allows them to interconnect with other devices.
- Ovens might know what time to cook a meal for you by communicating with your calendar on what time you are scheduled to be home.
- Smart home technology is currently being developed for all rooms within a house.

# Powerline Networking

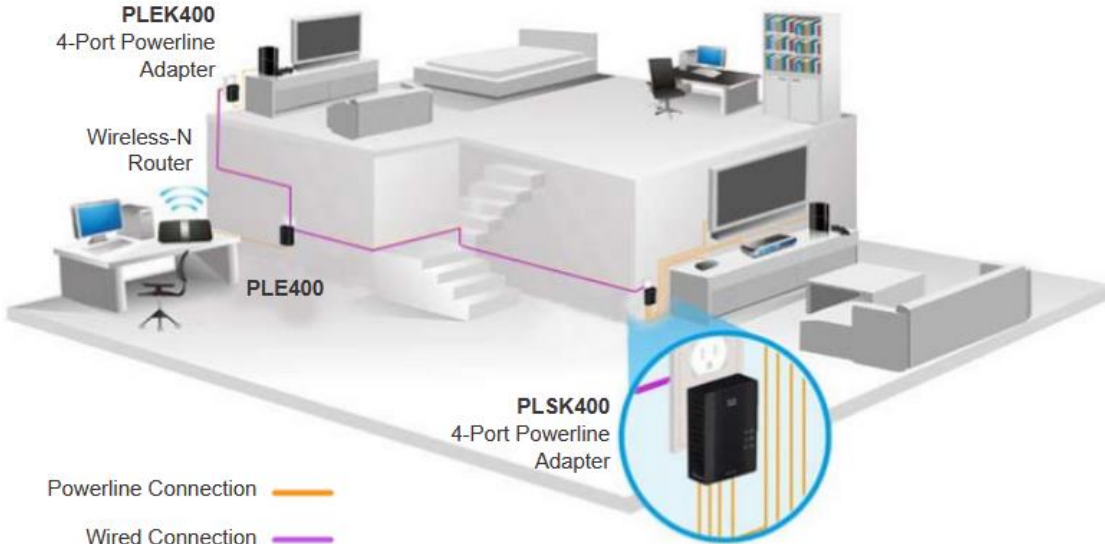

- Powerline networking can allow devices to connect to a LAN where data network cables or wireless communications are not a viable option.
- Using a standard powerline adapter, devices can connect to the LAN wherever there is an electrical outlet by sending data on certain frequencies.
- Powerline networking is especially useful when wireless access points cannot reach all the devices in the home.

# Wireless Broadband



In addition to DSL and cable, wireless is another option used to connect homes and small businesses to the internet.

- More commonly found in rural environments, a Wireless Internet Service Provider (WISP) is an ISP that connects subscribers to designated access points or hotspots.
- Wireless broadband is another solution for the home and small businesses.
- Uses the same cellular technology used by a smart phone.
- An antenna is installed outside the house providing wireless or wired connectivity for devices in the home.



# 1.8 Network Security

# Network Security

## Security Threats

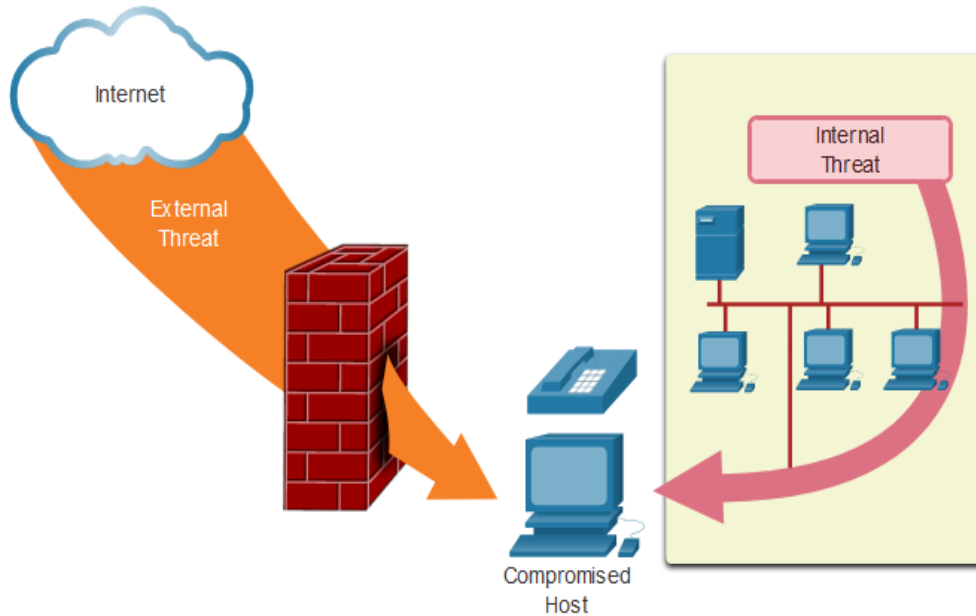

- Network security is an integral part of networking regardless of the size of the network.
- The network security that is implemented must take into account the environment while securing the data, but still allowing for quality of service that is expected of the network.
- Securing a network involves many protocols, technologies, devices, tools, and techniques in order to secure data and mitigate threats.
- Threat vectors might be external or internal.

# Network Security

## Security Threats (Cont.)

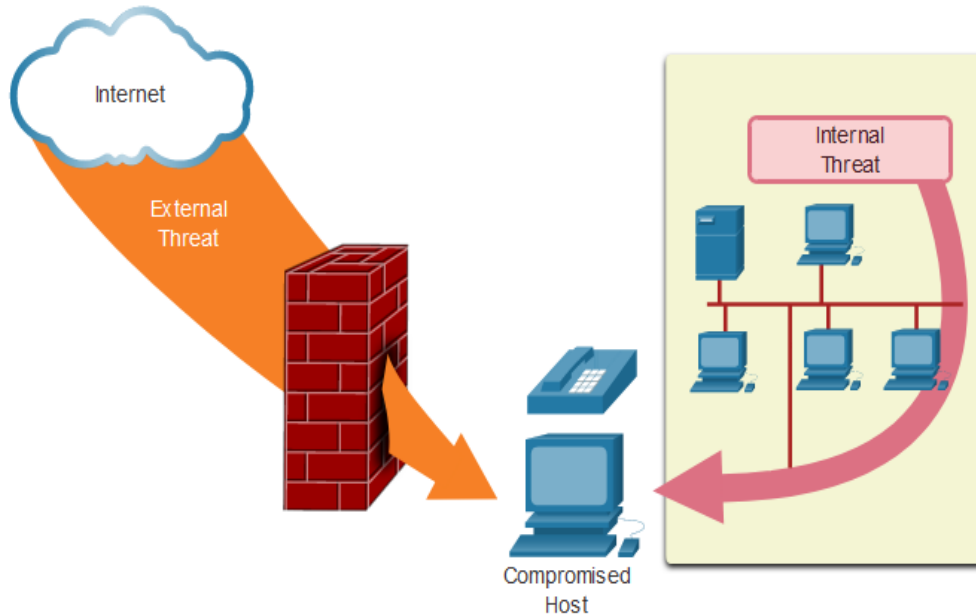

### External Threats:

- Viruses, worms, and Trojan horses
- Spyware and adware
- Zero-day attacks
- Threat Actor attacks
- Denial of service attacks
- Data interception and theft
- Identity theft

### Internal Threats:

- lost or stolen devices
- accidental misuse by employees
- malicious employees

# Network Security

## Security Solutions

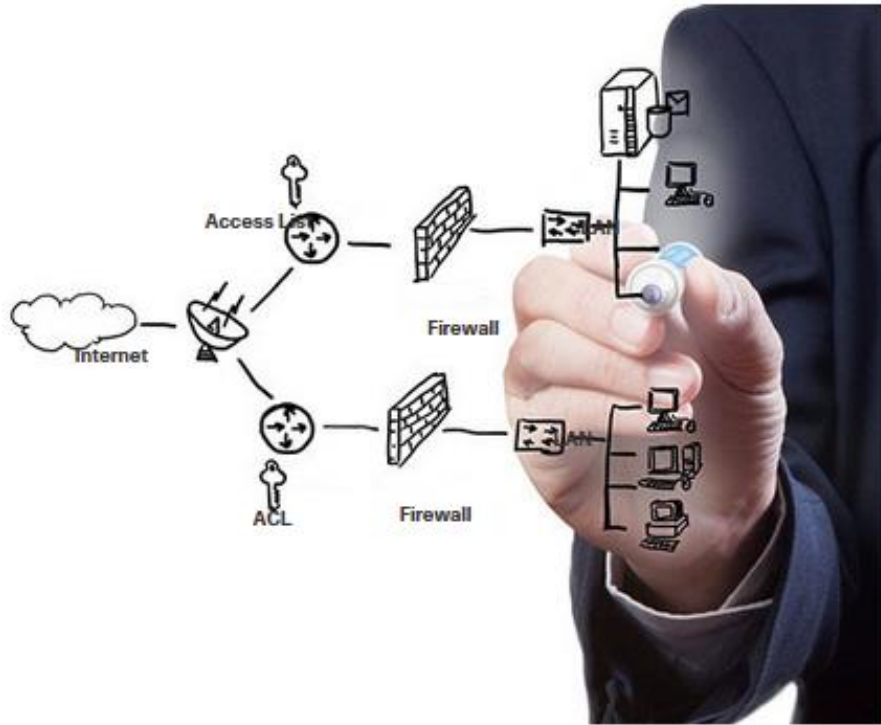

Security must be implemented in multiple layers using more than one security solution.

Network security components for home or small office network:

- Antivirus and antispyware software should be installed on end devices.
- Firewall filtering used to block unauthorized access to the network.

# Security Solutions (Cont.)

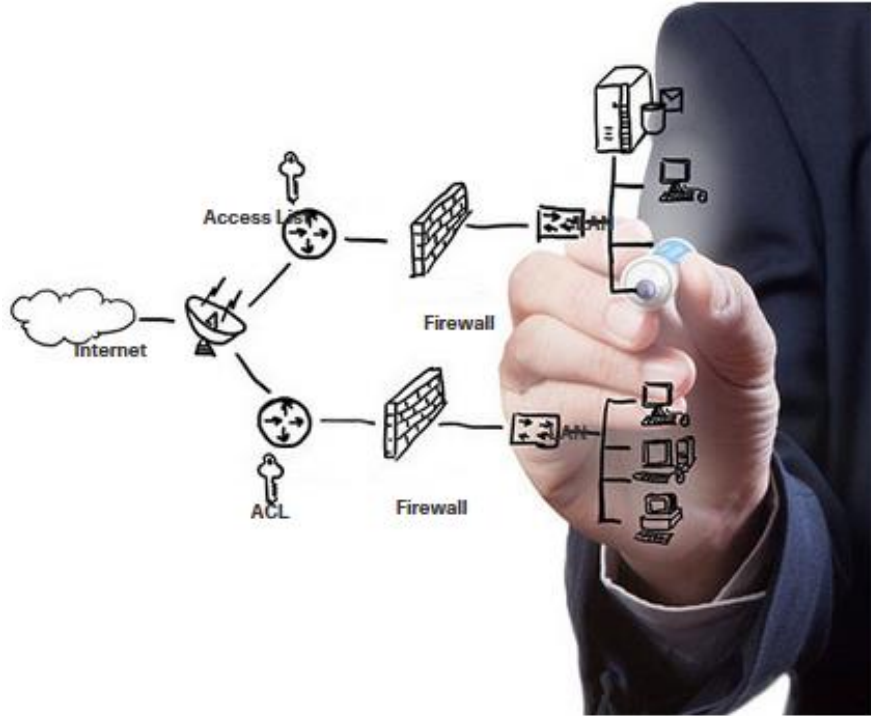

Larger networks have additional security requirements:

- Dedicated firewall system
- Access control lists (ACL)
- Intrusion prevention systems (IPS)
- Virtual private networks (VPN)

The study of network security starts with a clear understanding of the underlying switching and routing infrastructure.

# 1.9 The IT Professional

## Jr. Officer/ Officer - IT (Hardware & Networking)

📍 Bangladesh 📄 Permanent 🕒 Full-time

6 days ago

### Job Context

Officer of Hardware & Network Support is responsible to maintain, upgrade and manage Company's, hardware and networks. The system hardware, operating systems, software systems, internet setup, e-mail setup and related procedures adhere to organization's policies.

### Job Responsibilities

- Provide IT supports for desktop, laptop & also require troubleshoot all IT Equipment & Solving Problems (Printer, UPS, IPS, Switch Laptop & system in used).
- Physical network (LAN) configuration, Cabling, UTP Cable layout, troubleshooting & maintenance.
- Maintenance and Management of ETS, CCTV, ZKTeco Attendances & Access control Device, and other IT related equipment.
- Configure and Maintenance network device (Switch, Router) of TP-Link, D-Link, Tenda, Mikrotik.
- Must have good knowledge in MS Office, MS Excel, Power Point, Internet, etc.
- Installing and Update Antivirus, Operating systems (Windows XP, Windows 7, Windows 8.1, Mac, Windows 10,) & configuring out
- Communicate with vendors for technical support and program updates as needed to resolve.
- Investigating, diagnosing and solving all IT related equipment faults and resolve accordingly.
- Provide IT supports to user end IT assets.

Employment Status

[View & Apply](#)

## Network Engineer

### BANGLADESH INTERNET EXCHANGE TRUST (BDIX)



[View all jobs of this company](#)

### Vacancy

Not specific

### Job Responsibilities

- IP Core Network Design and Planning.
- Advance knowledge about Switching Network (STP, RSTP), Routing (OSPF, BGP).
- Advanced Switching and Routing knowledge on Cisco Router, Cisco Nexus L2 and L3, Mikrotik as well as Linux routing daemon (Bird, FRR).
- Strong knowledge about Linux Operating System (Redhat, Ubuntu, CentOS), Xenserver.
- Creating and implementing network security measures.
- Preferred Professional Certification: Cisco Certified Network Associate (CCNA), Red Hat Certified Engineer (RHCE)

### Employment Status

Full-time

### Workplace

## System Administrator

Dhaka Permanent Full-time

4 days ago

Apply easily

### Job Responsibilities

- Design, implementation and maintenance production network which are connected with ISP, Telco and Banks.
- Ensure security of production network.
- Managing all aspects of system monitoring and reporting (including 24/7 support for critical services)
- Ensuring system security, availability and performance
- Ensuring power backup, disk backup, and data recovery
- Maintenance production servers (Linux and Windows environment)
- Maintenance GIT and Jira
- Maintenance of networking and security devices like Cisco, Fortinate and Sophos devices
- Software deployment at Java and Python environment
- Database administration and maintenance (MySQL and PostgreSQL)

Employment Status

Full-time

Educational Requirements

Apply Now

## Jr. Officer/ Officer - IT (Hardware & Networking)

Bangladesh Permanent Full-time

6 days ago

### Job Context

Officer of Hardware & Network Support is responsible to maintain, upgrade and manage Company's, hardware and networks. This individual ensures that system hardware, operating systems, software systems, internet setup, e-mail setup and related procedures adhere to organizational values.

### Job Responsibilities

- Provide IT supports for desktop, laptop & also require troubleshoot all IT Equipment & Solving Problems (Printer, UPS, IPS, Switch, Router, Desktop PC, Laptop & system in used).
- Physical network (LAN) configuration, Cabling, UTP Cable layout, troubleshooting & maintenance.
- Maintenance and Management of ETS, CCTV, ZKTeco Attendances & Access control Device, and other IT related equipment.
- Configure and Maintenance network device (Switch, Router) of TP-Link, D-Link, Tenda, Mikrotik.
- Must have good knowledge in MS Office, MS Excel, Power Point, Internet, etc.
- Installing and Update Antivirus, Operating systems (Windows XP, Windows 7, Windows 8.1, Mac, Windows 10,) & configuring outlook.
- Communicate with vendors for technical support and program updates as needed to resolve.
- Investigating, diagnosing and solving all IT related equipment faults and resolve accordingly.
- Provide IT supports to user end IT assets.

View & Apply

Next >



# System Administrator

Berger Paints Bangladesh Limited - Dhaka, Bangladesh · 7 hours ago · 56 applicants

Easy Apply

Save

## About the job

### Key Accountabilities:

- Proactively manage the backup of all Windows System, Linux System & Network equipment.
- Monitor health status of all systems and applications through NMS and take corrective actions according to alert.
- Maintain System Center Configuration Manager and repositories.
- Administer different types of Database (MSSQL, Mongo & MySQL).
- Grow skill and gather knowledge for self-improvement and train teammates & users.
- Proactively maintain & deploy network equipments such as Router, Switch, VPN, Wireless Controller & Access Points, etc.
- Proactively administer Exchange Email, DNS, and ADDS, ADCS, ADFS, Distributed File Server, O365 Services, SharePoint and OneDrive for Business etc.
- Documenting the configuration of the system and abide by all the IT policies through change management procedure.
- Provide technical support for both hardware and software issues to our users and resolving help desk requests as per Berger ITIL process.

### Required Qualification:

- B.Sc. in CSE from any well reputed university.
- Practical knowledge on Azure/AWS cloud and Microsoft O365 will be preferred.
- Vendor certification on any Microsoft System Administration, CCNA & RHCA will be preferred.

### Required Technical Skill:

- OS/Virtualization platform: Linux, Windows, Hyper-V, VMWare.
- Database platform: MS SQL, MongoDB, MySQL.
- Cloud Platform: Microsoft Azure.

## Job Details

Seniority Level  
Associate

Industry  
Chemicals

Employment Type  
Full-time

Job Functions  
Information Technology

# DevOps Engineer (Senior)

Giga Tech Limited

Dhaka Permanent Full-time

13 hours ago

## Job Summary

We are looking for candidates for the position of DevOps Engineer (Senior)

## Job Description

Vacancy  
01

### Job Responsibilities

- Experience in production-grade DevOps engineering
- Design, build, and automate new solutions centered around the Kubernetes container
- Utilize DevOps technologies for efficient continuous integration, deployment and delivery employing best-in-class monitoring and self-healing techniques
- Writing scripts to develop, maintain, improve services for delivering cutting-edge DevOps functionality/infrastructure/environment that enables our engineers to build, release, and operate their software development projects
- Collaborate with our networking, infrastructure, and deployment teams in deploying, maintaining and administering software infrastructure
- SQL, Relational DB (MySQL, Oracle, etc.) & Non-relational DB Knowledge (MongoDB, PostgreSQL)
- Building and maintaining continuous integration systems in Jenkins
- Developing internal tools and workflows for large development teams
- Systems integration with third party and in-house systems
- Working experience of different K8s tools like helm, dashboard etc.
- Proven work experience with Docker, Docker Swarm, and Docker compose
- Strong background in Linux/Unix Administration with OS and Hardware level optimizations

< Previous

View & Apply

Next >

# The IT Professional CCNA



## The Cisco Certified Network Associate (CCNA) certification:

- demonstrates that you have a knowledge of foundational technologies
- ensures you stay relevant with skills needed for the adoption of next-generation technologies.

## The new CCNA focus:

- IP foundation and security topics
- Wireless, virtualization, automation, and network programmability.

New DevNet certifications at the associate, specialist and professional levels, to validate your software development skills.

Specialist certification validate your skills in line with your job role and interests.